

- Built-in Leveling Feature
- 2.5-7.0 Hz natural frequency range
- Viscous damping
- Internal springs
- Load Ranges from 11,500 lbs. (51 kN) to 52,000 lbs. (230 kN)
- Effectively isolates inertial and impact forces up to 99%
- Heavy-duty, low stress design

CUSTOM DESIGNS & SIZES ARE AVAILABLE

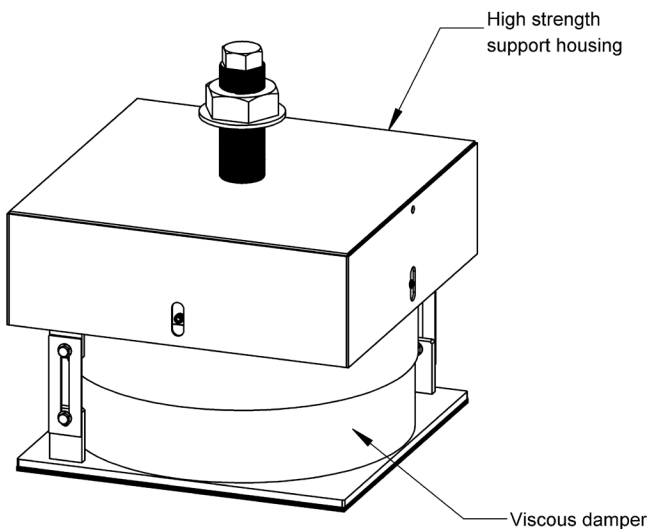

Precision leveling adjustment screw and lock nut

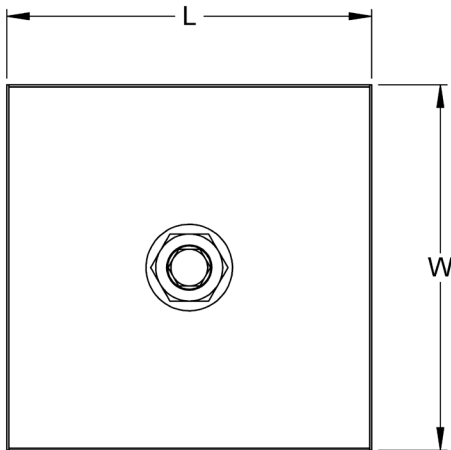
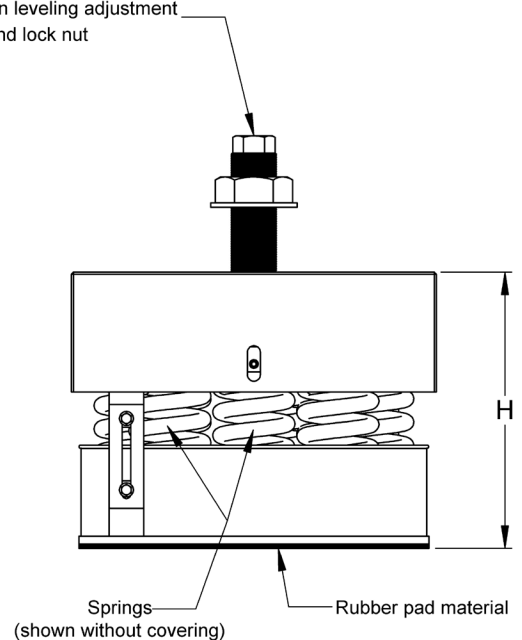

MODEL: VSXL HY/SPEED™ SPRING MOUNTS

MODEL NUMBER	L	W	H ±0.2" (5mm) Heights shown do not include 1" (24mm) of leveling adjustment		MAXIMUM STATIC LOAD		ESTIMATED WEIGHT	
			UNLOADED	MAX. CAP.	lbs	kN	lbs	Kg
VSXL2409-5-90	21.0 (535mm)	21.0 (535mm)	15.5 (394mm)	13.0 (330mm)	52000	230	690	315
VSXL2409-5-81					49000	217	690	315
VSXL2409-5-80					46000	205	675	305
VSXL2409-5-71					43000	192	670	305
VSXL2409-5-70					40000	179	660	300
VSXL2409-5-61					37000	166	655	300
VSXL2409-5-60					35000	153	645	295
VSXL2409-5-51					32000	141	640	290
VSXL2409-5-50					29000	128	630	285
VSXL2409-5-42					28750	128	635	288
VSXL2409-5-41					26000	115	625	285
VSXL2409-5-40					23000	102	615	280
VSXL2409-5-22					17300	77	605	275
VSXL2409-5-04					11500	51	600	275

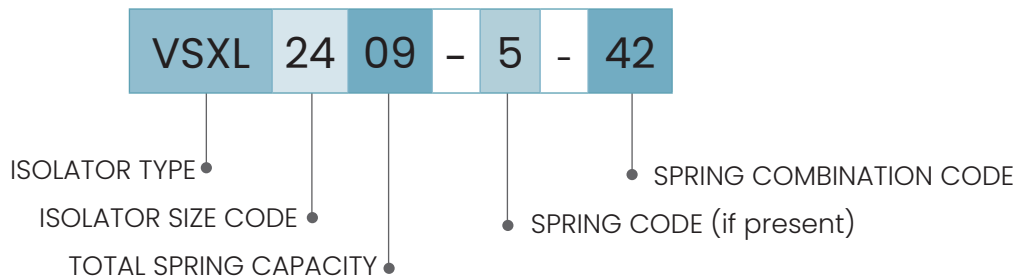

TYPICAL APPLICATIONS

- Stamping Presses
- Hydraulic Presses
- Forging Presses
- Mills
- Turbines
- Pumps, Blowers
- Building isolation
- Centrifuges

NOTE: Isolator data subject to change without notice.

02/24/2025

